

ZIMX SCOOTERS

by



Model : NEO-MAX

FREESTYLE / STUNT SCOOTER

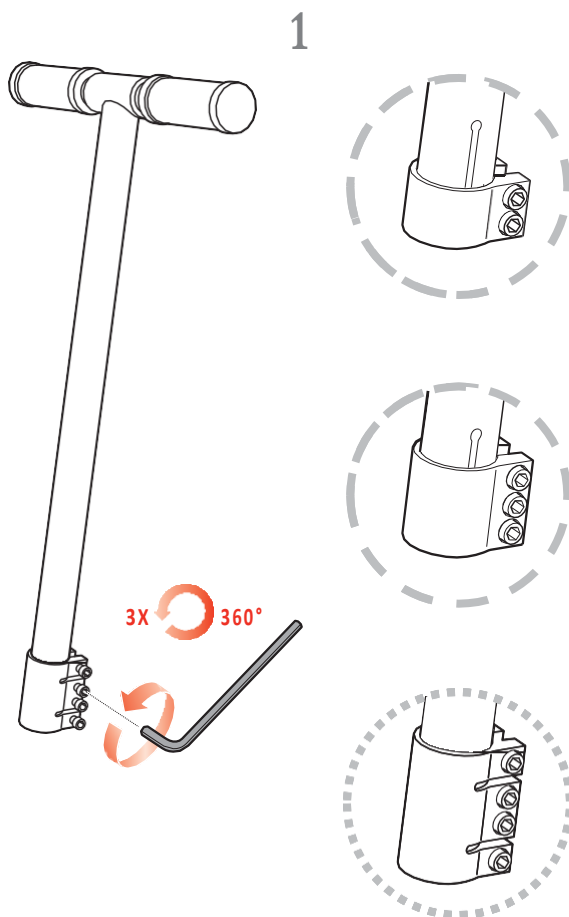
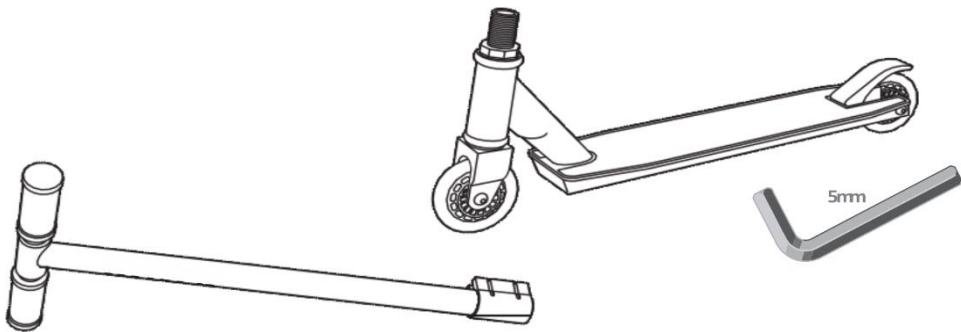

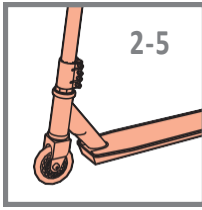

2

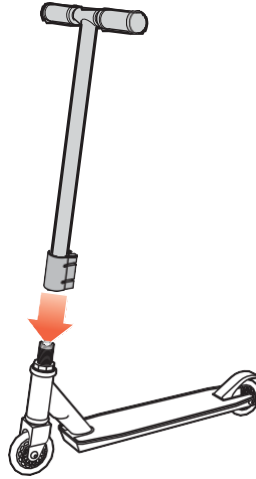
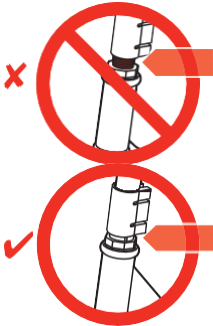

3

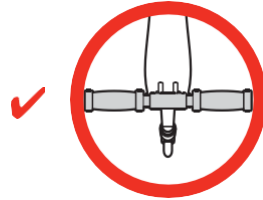
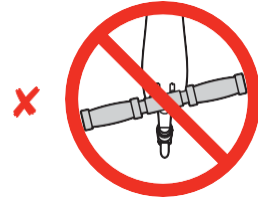

4

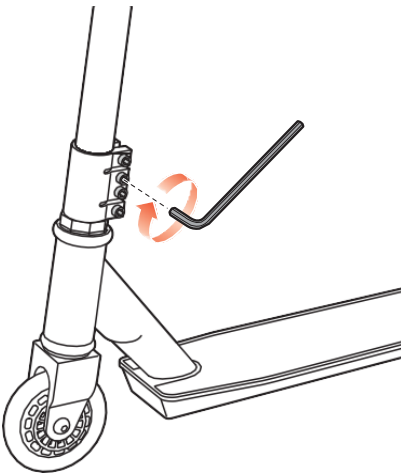

5

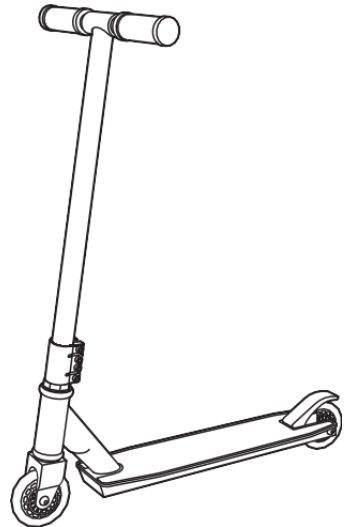

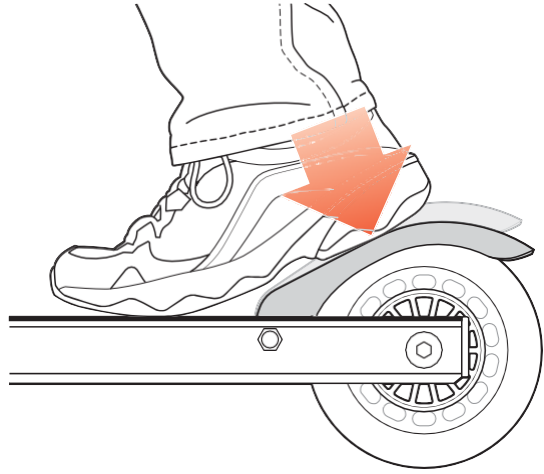

WARNING. To avoid serious injury:

Adult supervision always recommended.

This is sport/transport equipment.

Parents and carers should ensure that children are properly instructed in the use of this product.

Hold handlebars at all times.

Ride outdoors in places that allow you to improve your skills, and NEVER in traffic, on roads or near motor vehicles, where serious accidents can happen. Watch your surroundings for pedestrians, bike, skateboard, scooter and other riders. Use in areas free from hazards such as poles, hydrants, and parked cars.

Wet weather impairs traction, braking and visibility.

Never use near streets, swimming pools, hills, or steps. Use on smooth, dry, paved surfaces; avoid excessive speeds associated with downhill rides. Don't ride on loose debris (such as rocks, gravel or sand), or speed humps. Do not ride in the dark.

Always wear shoes when using this product.

Allow only one rider at a time on this product.

Do not touch the brake after using, it will be hot.

Like any other moving product, riding this product can be a dangerous activity and may result in injury even when used with proper safety precautions.

All freestyle sport scooters are designed for use by more accomplished and capable riders who may have developed scootering skills and wish to advance and improve their riding techniques. Even very good riders need to be careful.

While these are some of our strongest scooter products, that does not eliminate risks presented by scooter riding.

Age and Weight Limits

Freestyle / Stunt scooter is not designed for children under age 8.

Maximum rider weight 100 kg (220 lb).

Protective Equipment

Always wear protective gear - helmet, elbow, knee and wrist guards (note parents should evaluate whether their child's use of wrist guards may impair their ability to hold handlebars).

Failure to heed product warnings, or to exercise caution, increases risk of injury!

Where and How to Ride

Stop by pushing on brake with foot.

Learn to fall (by rolling if possible) without the product.

Learn with a friend or parent to help.

This product was manufactured for performance and durability. Trick riding can, over time, stress or damage any product.

Risk of injury increases as degree of trick difficulty and product stress increases.

Rider assumes all risks associated with trick riding.

You may see people in videos, or people you know, doing tricks. These people have been practicing for a long time and accept the risks of trick riding. Do not assume you can try tricks without great risk.

Check local laws regarding where and how you may use your product.

Maintenance

Always inspect product before riding and regularly maintain it. Replace worn or damaged parts immediately.

Check that the steering system is correctly adjusted and that all connection components are firmly secured and not broken.

Check brake for proper function. When you push on the brake with your foot, brake should provide positive braking action.

Under normal circumstances and conditions, the wheels and bearings are maintenance free.

Regularly check that the various screwed parts are tight.

No modifications can be made that can impair safety.

Wipe with a damp cloth to remove dirt.

If repairs are needed, bring product to a bicycle repair shop.

Use only authorized ZIMX replacement parts.

Limited Warranty

This Limited Warranty is the only warranty for this product. There is no other express or implied warranty.

The manufacturer warrants this product to be free of manufacturing defects for a period of 6 months from the date of purchase. This Limited Warranty will be void if the product is ever used in a manner other than for recreations or transportation, modified in any way, or rented.

Failure to use common sense and heed the above warnings further increases risk of serious injury. Use at your own risk and with appropriate and serious attention to safe operation.

Use caution.

Printed in China for UKBIGBUY.COM

New Age Group
T/A UKBIGBUY.COM
ZIMX.UK
B16 0HG,
United Kingdom
+44 (0) 121 454 7589
info@ukbigbuy.com
info@zimx.uk

21L_210322

Copyright © 2010-2021 UKBIGBUY.COM. All rights reserved. ZIMX, the ZIMX logo design, and X logo design are among the registered trademarks of NEW AGE GROUP in the United Kingdom and/or select foreign countries.



EN 14619

www.ukbigbuy.com

www.zimx.uk

ZIMX

SCOOTERS

by



UKBIGBUY.com

Saving you money every day